

Specification of: DDM 10/8 E6G3603 3F 4P 1V +SCT == 6N02XA

High performance centrifugal fan DDM

Double width, double inlet (DWDI), direct drive, forward curved blades fan. Lap-jointed scroll made of galvanized steel (EN 10142), assembled through a high-technology roller-locked seaming. Straight cut off plate at fan discharge. Impeller with forward curved blades of galvanized steel plate, directly mounted on a "External Rotor" motor for no transmission losses. Closed (IP 55) frame, three-phase, single speed motor, usable at 400 V, 50 Hz. Built-in thermal protection device available as option. Maintenance free, integral vibration isolators, self aligning ball bearings. Dynamically balanced according to DIN ISO 21940-11. With mounted terminal box. Air performance ratings according to AMCA 210-99 (Fig. 12), UNI 10531 (Fig 30c and par. 29.2 f) and ISO 5801 (Fig. 69 c and par. 30.2 f).

Technical data of the fan: DDM 10/8 E6G3603 3F 4P 1V +SCT == 6N02XA

[fulfills the ErP requirements 2015](#)

Description	Value Dimension
Specified duty point	
Actual duty point	
Installation acc. DIN 24163 Part 1	B
Reference density (Rho1)	1.20 kg/m ³
Medium temperature (t)	20 C
Fan weight	24 kg
Rated data	
Phases-Voltage-Frequency	3~230/400-50 V-Hz
Number of poles:	4
Motor rating (P _N)	0.55 kW
Rated motor speed (n _N)	1410 min ⁻¹
Rated motor current (I _N)	4,3/2,5 A
operational limits	
Max. absorbed power (P _{1max})	1.376 kW
Temperature range of conveying medium (t _{min} ... t _{max})	-20...40 C
ErP-Data at best efficiency and density - kg/m³	
measurement- / efficiency category	B / total
design status of VSD	without VSD
overall efficiency (ETA _{opt})	45.2 %
achieved efficiency grade (N _{ist})	51.8
required efficiency grade in 2013 / 2015 (N)	42 / 49
Air flow rate (V _{opt})	2739 m ³ /h
pressure rise (dp _{opt})	556 Pa
Fan speed (n _{vopt})	1350 min ⁻¹
motor power input (P _{1opt})	0.931 kW
specific ratio (d _{dpopt})	1.005

Fan curve to DDM 10/8 E6G3603 3F 4P 1V +SCT == 6N02XA

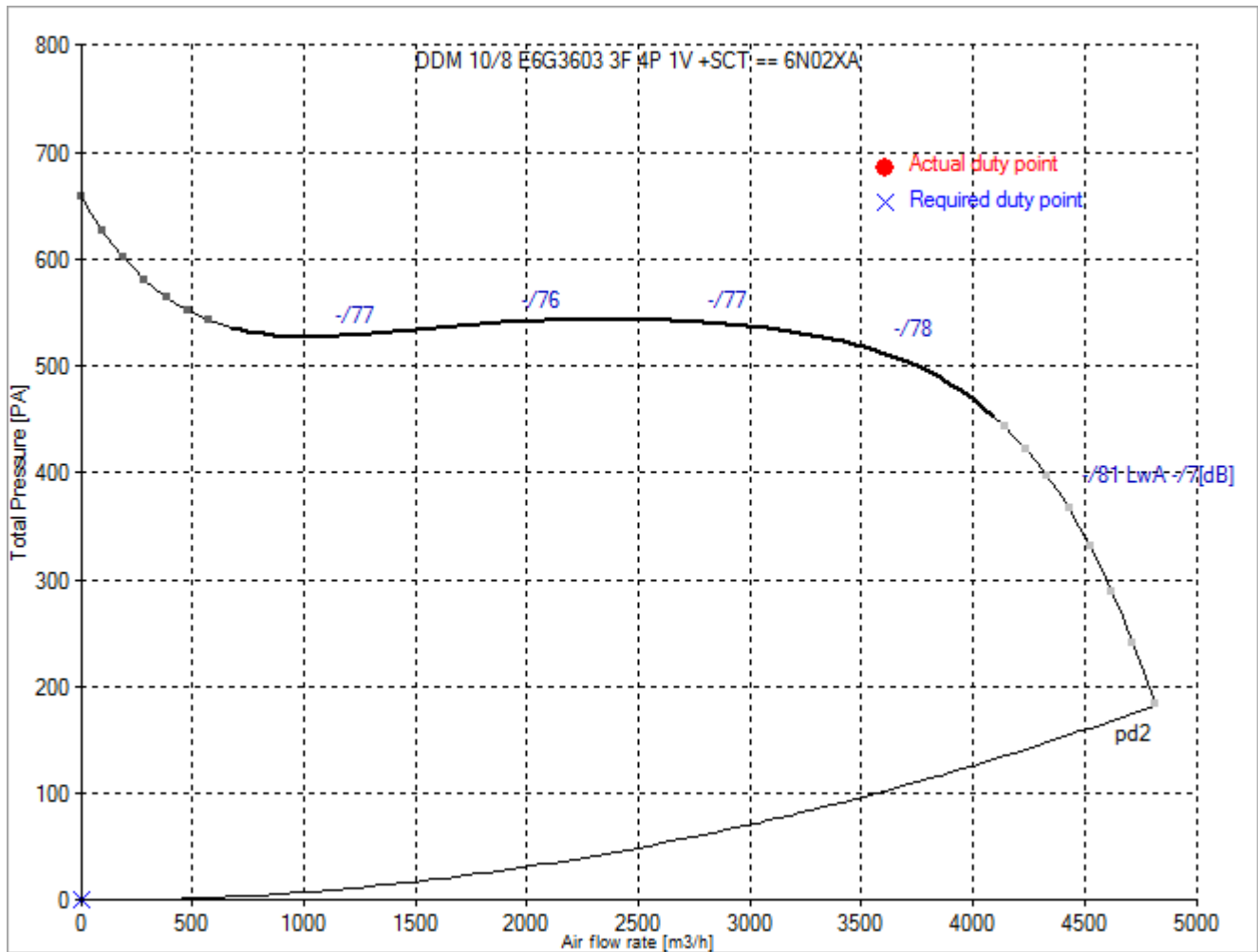

Dimensions to DDM 10/8 E6G3603 3F 4P 1V +SCT == 6N02XA

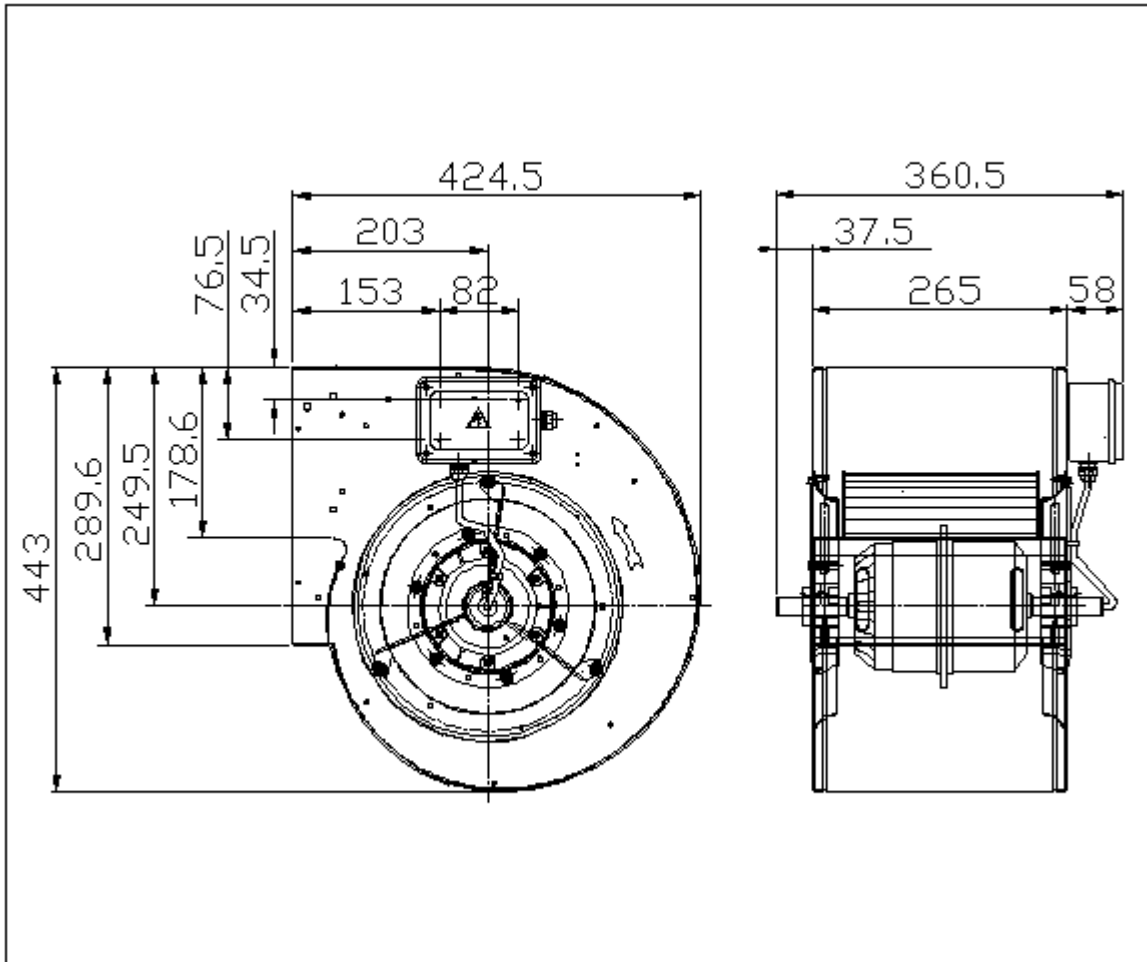

Rotation:
Handing:

RD
90

Wiring diagram of the fan DDM 10/8 E6G3603 3F 4P 1V +SCT == 6N02XA

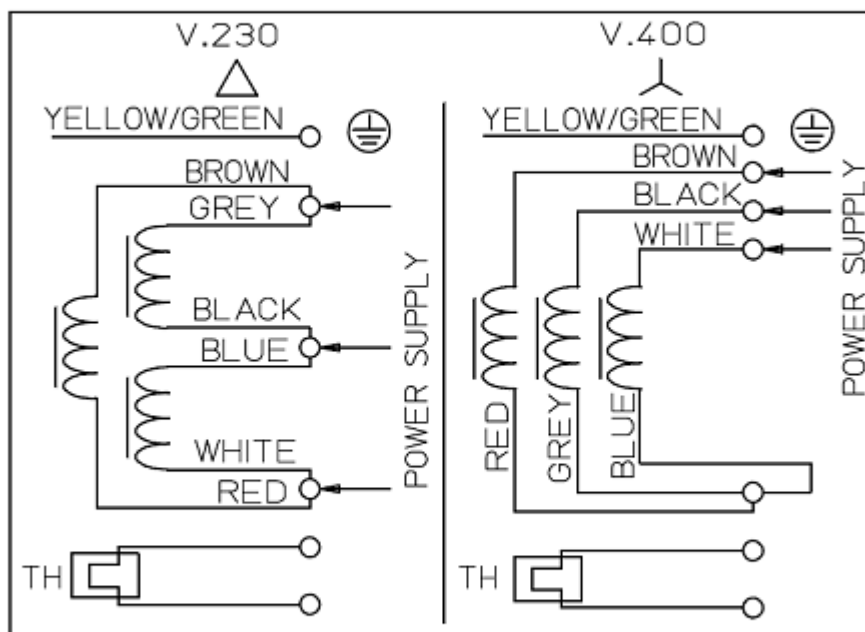

19-02-2015 78

Wiring diagram for connection to: [mains - terminal box - motor](#)
Rotation: [LG](#)